

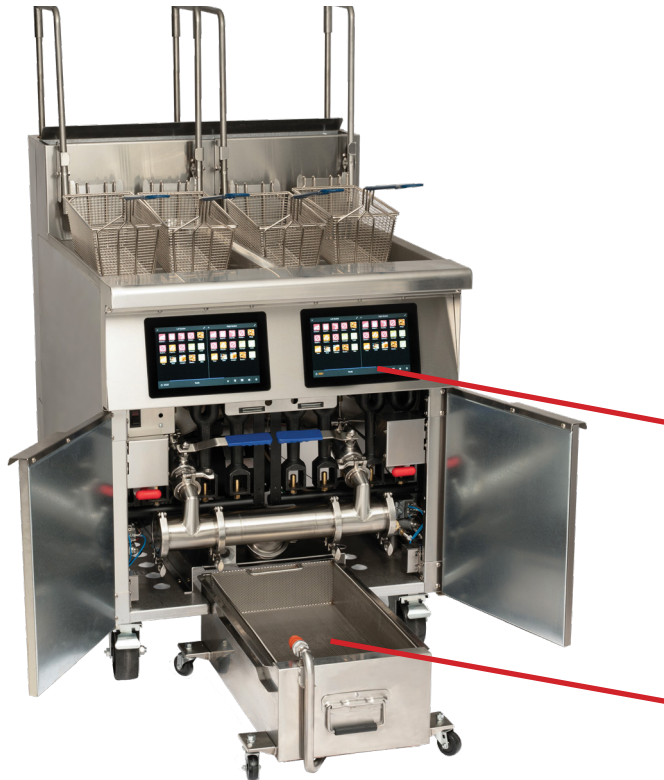

ELECTRIC

SPACE SAVER FRYER FILTER SYSTEMS



IFSSP250E

MODEL NUMBERS

| | |
|-----------|-----------|
| IFSSP250E | IFSSP175E |
| IFSSP350E | IFSSP275E |
| IFSSP450E | IFSSP375E |
| IFSSP550E | IFSSP475E |
| IFSSP650E | IFSSP575E |
| IFSSP650E | IFSSP675E |

- Add suffix "T" for Electronic Thermostat
- Add suffix "C" for Computer Controls
- Add suffix "DC" for Digital Touchscreen Controls
- Suffix "E" denotes Immersed Elements
- Suffix "EU" denotes Tilt-Up Elements



**Touch Screen
Digital Controls
Now Available**

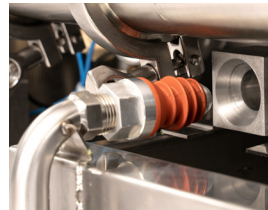

**Hands-free
Filter Connection
System**

FILTER PACKAGE CHOICES

- Up to six fryers can be battered into one fryer/filter system.
- Available for 50 and 75 lb (27 and 41 Liters) oil capacity fryers.
- Available with Snap Action Thermostats, Electronic Thermostats or Computer Controls.

UNIQUE FILTER PAN DESIGN

- Filter pan is designed for maximum oil return
- Stainless steel construction is easy to clean and has a professional look.
- Positive-latching filter paper holder holds paper in place for optimal filtration.
- Quick disconnect connection offers quick and safe connection of the filtered oil back into the frypots.
- All oil drain and return lines are internally plumbed for convenience and safety.

ROLLER-PUMP

- 5.5 GPM pump with a 1/3 HP motor speeds up the filtering process.
- Can pump oil into a disposal vat up to 20 feet away.

EXTERIOR FEATURES

- Continuous cabinet provides a professional look.
- 5" (127 mm) deep continuous stainless steel front landing ledge.
- Stainless steel precision welded frypot
- Includes casters, joiner strips, filter starter kit and fryer tip brush

LOCATED UNDER FRYERS

- Filter location under fryers saves valuable space.
- Internally plumbed oil drain and return line.



1128 Sherborn Street | Corona, CA 92879 | 800.343.7790 | imperialrange.com | imperialsales@imperialrange.com

©2026 Imperial Commercial Cooking Equipment. Imperial reserves the right to change specifications at any time without prior notice and without any obligation for past or future



ELECTRIC

SPACE SAVER FRYER FILTER SYSTEMS

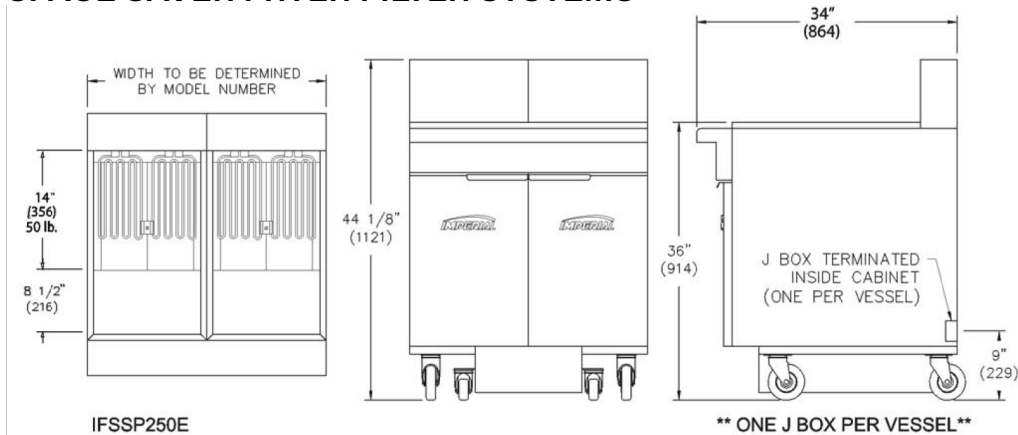

SPACE SAVER FRYER/FILTER SYSTEMS

| MODEL | OIL CAPACITY | WIDTH | FRYERS | SHIP WEIGHT KG | SHIP WEIGHT LBS |
|----------------|----------------|--------------|--------|----------------|-----------------|
| IFSSP250E/EU | 50 LBS. (41 L) | 31"(787MM) | 2 | 284 | 626 |
| IFSSP350E/EU | 50 LBS. (41 L) | 46½"(1181MM) | 3 | 389 | 856 |
| IFSSP450E/EU | 50 LBS. (41 L) | 62"(1575MM) | 4 | 495 | 1092 |
| IFSSP550E/EU | 50 LBS. (41 L) | 77½"(1969MM) | 5 | 655 | 1445 |
| IFSSP650E/EU | 50 LBS. (41 L) | 93"(2362MM) | 6 | 770 | 1698 |
| IFSSP175E/EU | 75 LBS. (51 L) | 19½"(495MM) | 1 | 171 | 376 |
| IFSSP275E/EU | 75 LBS. (51 L) | 39"(911MM) | 2 | 268 | 590 |
| IFSSP375E/EU | 75 LBS. (51 L) | 58½"(1486MM) | 3 | 390 | 860 |
| IFSSP475E / EU | 75 LBS. (51 L) | 78"(1981MM) | 4 | 513 | 1130 |
| IFSSP575E / EU | 75LBS.(51L) | 97½"(2477MM) | 5 | 635 | 1400 |
| IFSSP675E / EU | 75 LBS. (51 L) | 117"(2972MM) | 6 | 758 | 1670 |

FILTER ELECTRICAL REQUIREMENT

| VOLTAGE | PHASE | HZ | AMPS |
|---------|-------|----|------|
| 115V | 1 | 60 | 6.8 |

ELECTRICAL REQUIREMENT PER FRYER

| MODEL | VOLTS | PHASE | HZ | AMPS |
|---------|-------|-------|----|------|
| 50 LBS. | 208 | 3 | 60 | 47 |
| 50 LBS. | 240 | 3 | 60 | 41 |
| 50 LBS. | 480* | 3 | 60 | 21 |
| 75 LBS. | 208 | 3 | 60 | 57 |
| 75 LBS. | 240 | 3 | 60 | 50 |
| 75 LBS. | 480* | 3 | 60 | 25 |

* For export only

6ft (1829 mm) power cord with 3 prong plug provided

| MODEL | DIMENSIONS | CRATED DIMENSIONS |
|----------------|--|--|
| IFSCB250E / EU | 31" W X 34" D X 44 1/8" H (787 MM X 864MM X 1121MM) | 32½"W X 39"D X 49½"H (826MM X 991MM X 1257MM) |
| IFSCB350E / EU | 46½" W X 34" D X 44 1/8" H (1181 MM X 864MM X 1121MM) | 48" W X 39"D X 49½" H (1219 MM X 991MM X 1257MM) |
| IFSCB450E / EU | 62" W X 34" D X 44 1/8" H (1575 MM X 864MM X 1121MM) | 63½" W X 39"D X 49½" H (1613 MM X 991MM X 1257MM) |
| IFSCB550E / EU | 77½" W X 34" D X 44 1/8" H (1969 MM X 864MM X 1121MM) | 79" W X 39"D X 49½" H (2007 MM X 991MM X 1257MM) |
| IFSCB650E / EU | 93" W X 34" D X 44 1/8" H (1969 MM X 864MM X 1121MM) | 94½" W X 39"D X 49½" H (2400 MM X 991MM X 1257MM) |
| IFSCB175E / EU | 19½" W X 39" D X 46½" H (495 MM X 991MM X 1181MM) | 26" W X 41" D X 53½" H (660 MM X 1041MM X 1359MM) |
| IFSCB275E / EU | 39" W X 40½" D X 44 1/8" H (911 MM X 1029MM X 1121MM) | 40½" W X 43" D X 49½" H (1029 MM X 1092MM X 1257MM) |
| IFSCB375E / EU | 58½" W X 40½" D X 44 1/8" H (1486 MM X 1029MM X 1121MM) | 40½" W X 43" D X 49½" H (1524 MM X 1092MM X 1257MM) |
| IFSCB475E / EU | 78" W X 40½" D X 44 1/8" H (1981 MM X 1029MM X 1121MM) | 40½" W X 43" D X 49½" H (2019 MM X 1092MM X 1257MM) |
| IFSCB575E / EU | 97½" W X 40½" D X 44 1/8" H (2477 MM X 1029MM X 1121MM) | 40½" W X 43" DX 49½" H (2515 MM X 1092MM X 1257MM) |

OPTIONS AND ACCESSORIES

- Automatic basket lifts with computerized controls
- Manual controlled basket lifts
- Gas shut off valve, 3/4" N.P.T.
- Stainless steel tank cover
- Stainless steel side drain shelf
- Stainless steel side splash
- Manual timer
- Goofier Declogger Rod
- Sediment Scooper
- Filter paper 40# thickness, 20 microns, 100 sheets per box

CLEARANCE REQUIREMENTS

For use only on non-combustible floors with legs or casters. Provide 0" clearance from non-combustible surfaces and 6" (152 mm) from combustible surfaces.



MADE IN USA



1128 Sherborn Street, Corona, CA 92879 | 800.343.7790 | imperialrange.com | imperialsales@imperialrange.com

©2026 Imperial Commercial Cooking Equipment. Imperial reserves the right to change specifications at any time without prior notice and without any obligation for past or future